

www.UltrasonicMetallurgy.com

Ultrasonic vibrations in metallurgy... with **MMM** Technology

Degassing of Al alloys

Grain refinement of Al alloys

by M. Prokic

MP Interconsulting
Marais 36,
2400 Le Locle, Switzerland
www.UltrasonicsWorldGroup.com

Phone: +41-32-9314045
Fax: +41-32-9314079
www.mpi-ultrasonics.com
mpi@mpi-ultrasonics.com

Patent

European Patent Application (related to MMM technology): EP 1 238 715 A1
Multifrequency ultrasonic structural actuator
Applicant: **Prokic Miodrag**, MP Interconsulting, 5.03.2001 – 11.09.2002

Outline

- Lightweight Alloys: Weight Reduction and Energy Efficiency
- Ultrasound-Assisted Liquid Metal Treatment
- Conclusions and Future Perspectives

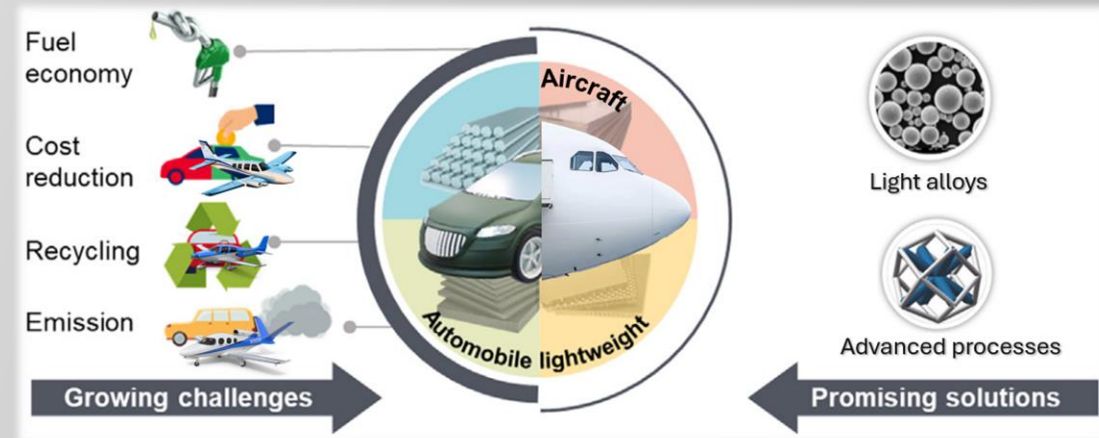

Adapted from Wen Zhang and Jun Xu. 2022

Lightweight Alloys: Weight Reduction and Energy Efficiency

In recent years, the **pressure** to improve **energy** efficiency and **reduce** environmental impact has been transforming the **automotive and aerospace industries**.

Aluminum, magnesium, and titanium alloys, with excellent specific strength, stiffness, and cost-effectiveness, **play an essential role in the present and future** of these industries.

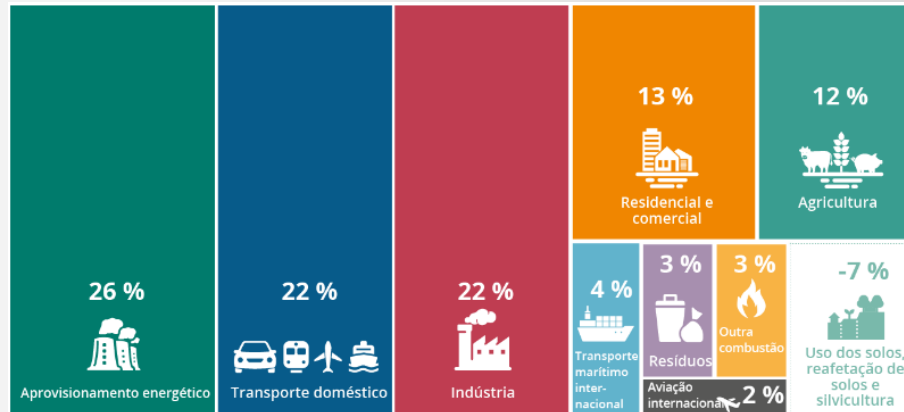

What are the sources of greenhouse gas emissions in the EU?

Infographic (static): Published 28 Nov 2022|Modified 29 Aug 2023

Lightweight Alloys: Weight Reduction and Energy Efficiency

Shaping the Future – **Innovation** and **Sustainability**

- **Processing** Methods 
- **New Materials** 
- **Design** Optimization: Topology Optimization, AI, and ML 
- Use of **Recyclable** Materials and Eco-efficient Processes 



Lightweight Alloys: Weight Reduction and Energy Efficiency

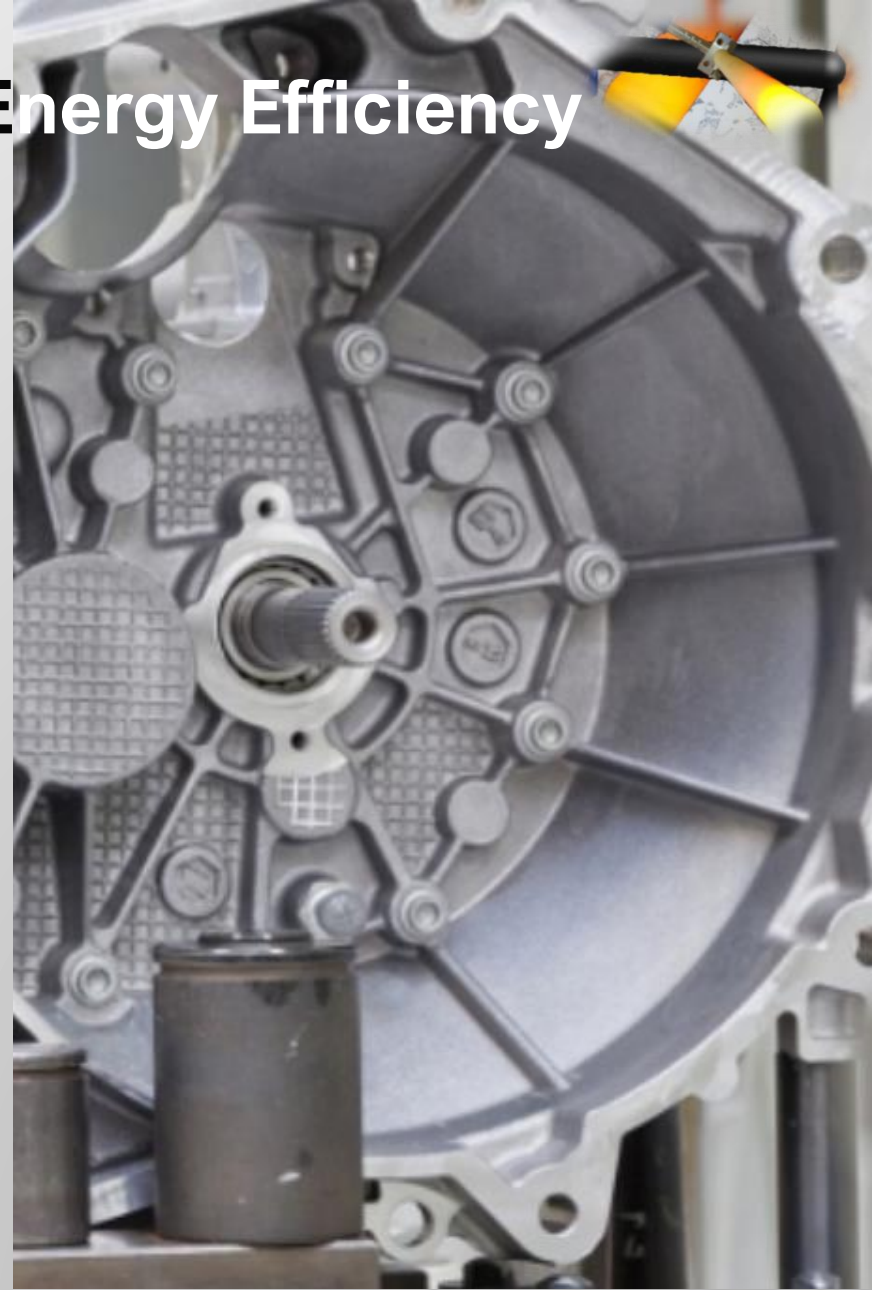

New Trends in Manufacturing

The use of **new** processes, or "**hybrid**" processes, to work with lightweight alloys is increasingly becoming a necessity.

Achieving lightweight components requires a holistic approach, combining **materials science**, **engineering design**, and **innovative manufacturing technologies** tailored for the "new" manufacturing era.

Aluminum and **magnesium alloys** play a crucial role in this strategy due to their advantageous properties and versatility.



Lightweight Alloys: Weight Reduction and Energy Efficiency

The evolution of aluminum in the European automotive industry can be divided into four phases:

1980: Powertrain use: engine blocks and transmissions.

1990-2005: Expansion to body panels (hoods, doors, roofs) using 5000/6000 series alloys, joined by laser welding, adhesives, and rivets.

2010-2020: Manufacturing structural components (pillars, suspensions) with ultra-high-strength alloys via casting.

Present and Future: Vehicles with aluminum and magnesium alloy components, optimized for battery weight, driven by electrification and space frame design.



From YouTube



Ultrasound-Assisted Liquid Metal Treatment

... US equipment set up in the foundry environment



Ultrasound-Assisted Liquid Metal Treatment

... Cavitation in Metallurgy

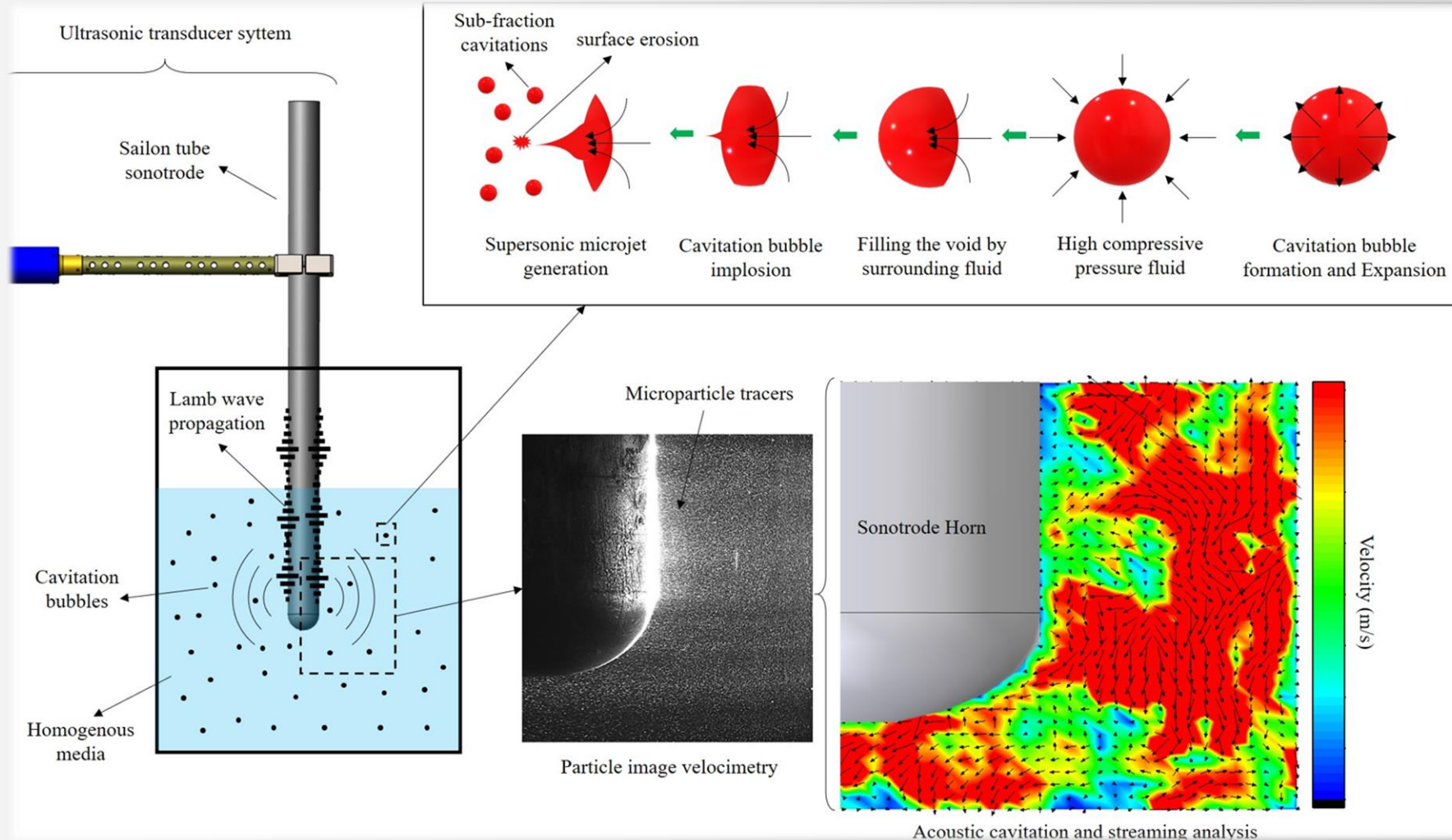

Ultrasound-Assisted Liquid Metal Treatment

From laboratory research...

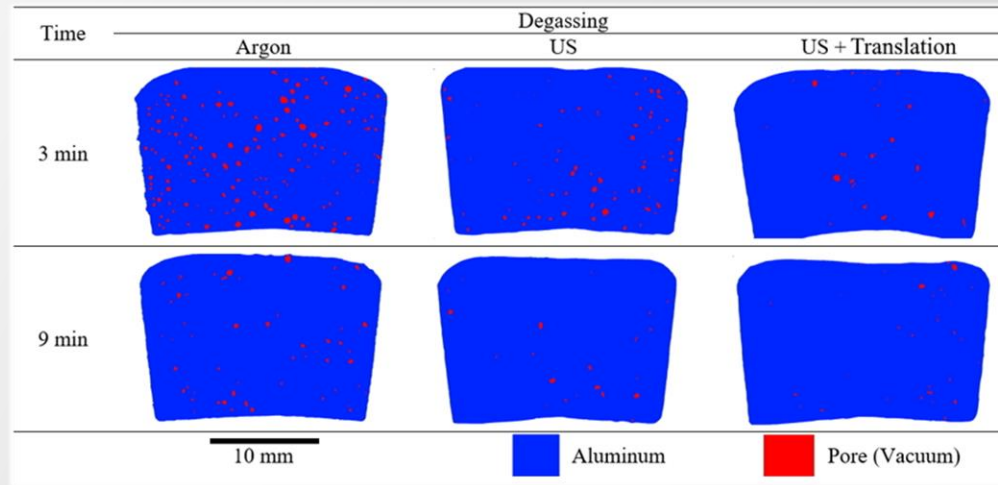
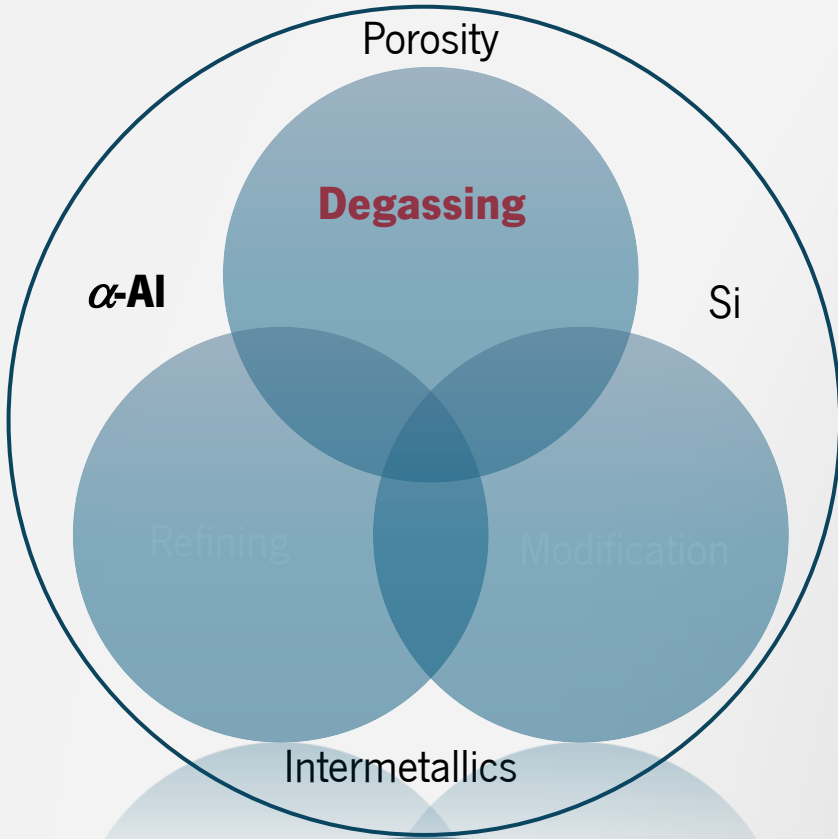

Degassing	Porosity in Samples Solidified in Vacuum	
	Avg. Pore Count (-)	
0 min	No degassing	258±32
3 min	Argon	172±16
	US	39±18
	US + Translation	80±15
9 min	Argon	60±21
	US	28±14
	US + Translation	34±15

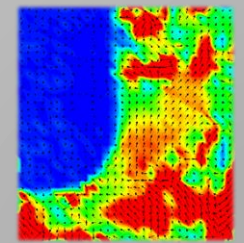
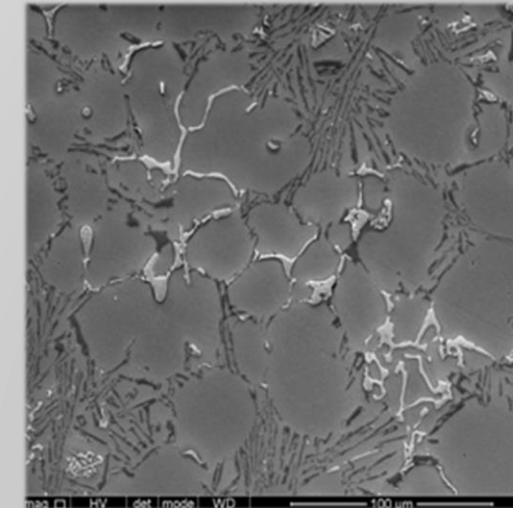
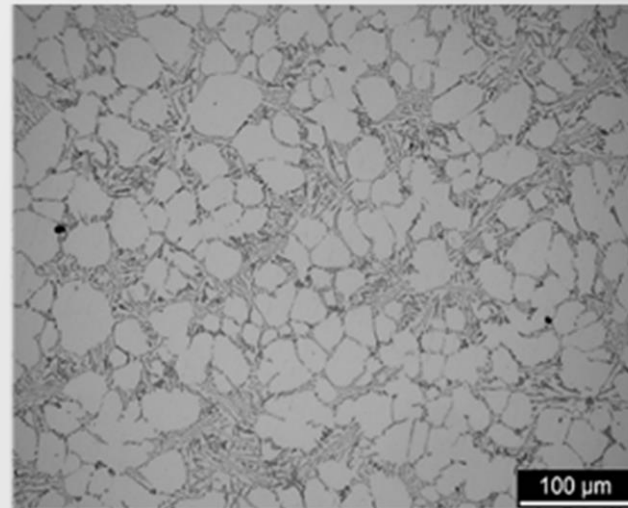

Ultrasound-Assisted Liquid Metal Treatment

From laboratory research...

Isothermal Process ($\Delta T \approx 0 \text{ }^\circ\text{C}$)

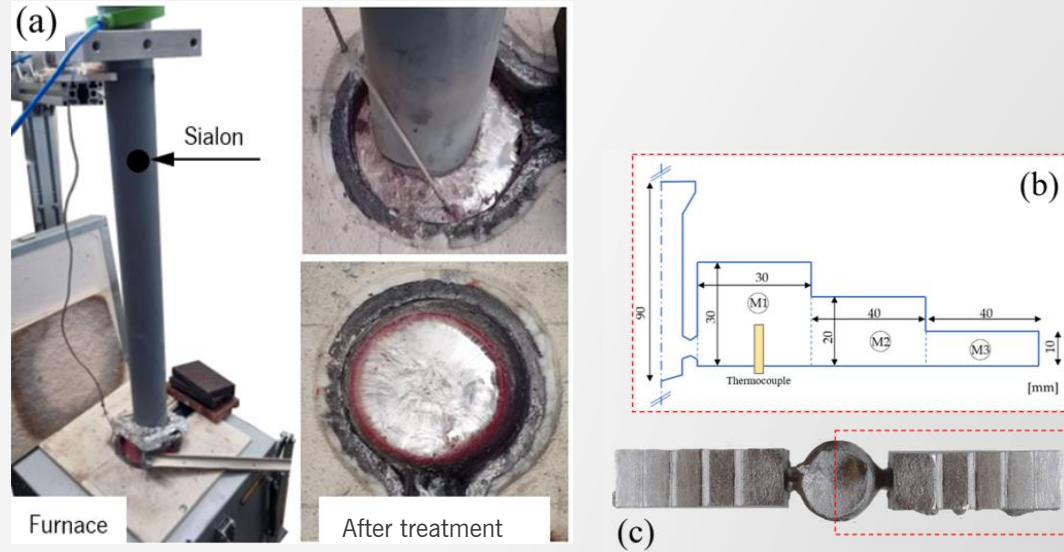

(a) Application of SiAlON sonotrode in the melt, (b) mold and (c) cast specimen.

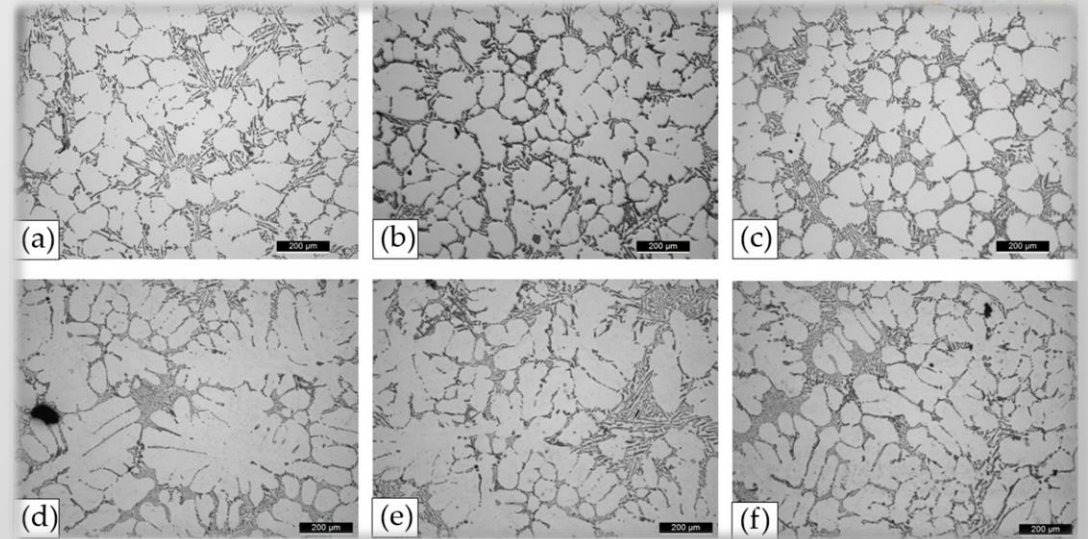

Ultrasound-treated melt in the (a) M1, (b) M2 and (c) M3 modules.
Non-treated melt in the (d) M1, (e) M2 and (f) M3 modules.

AlSi7Mg alloy
 $T = 700 \text{ }^\circ\text{C}$
 US MMM with $f = 19.8 \pm 0.4 \text{ kHz}$
 $P = 400 \text{ W}$

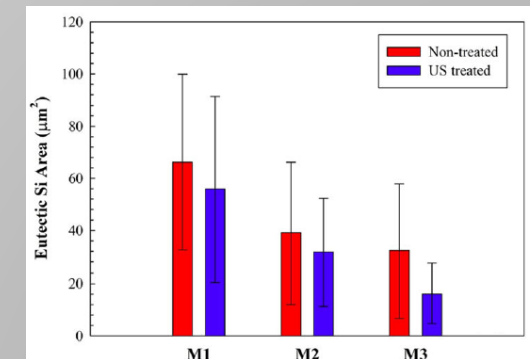

Characterization of eutectic Si

Ultrasound-Assisted Liquid Metal Treatment

From laboratory research...

Continuous Process

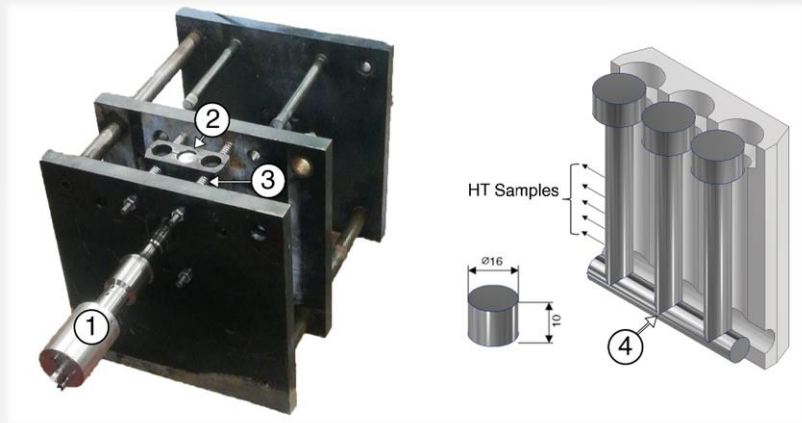

Set-up. (1) PZT transducer, booster and waveguide; (2) Steel mold; (3) and compression springs; (4) sample.

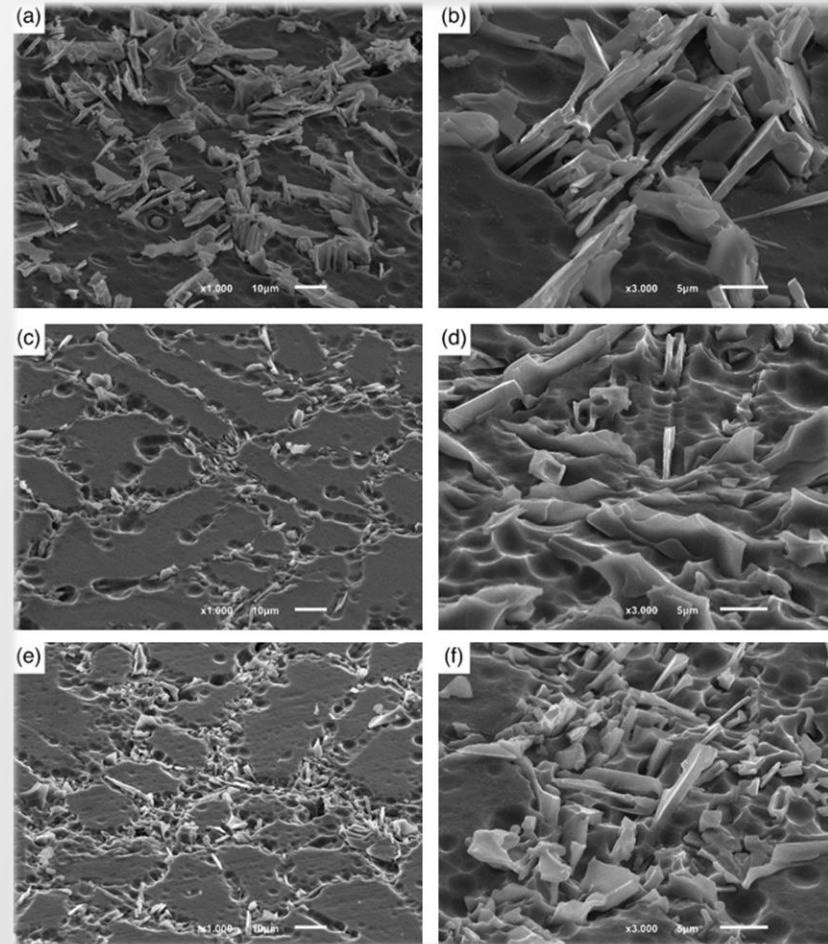

SEM micrographs of the morphology of the fragmented eutectic silicon of (a) and (b) sample A; (c) and (d) sample B; (e) and (f) sample C. (magnification x 1000 and x 3000).

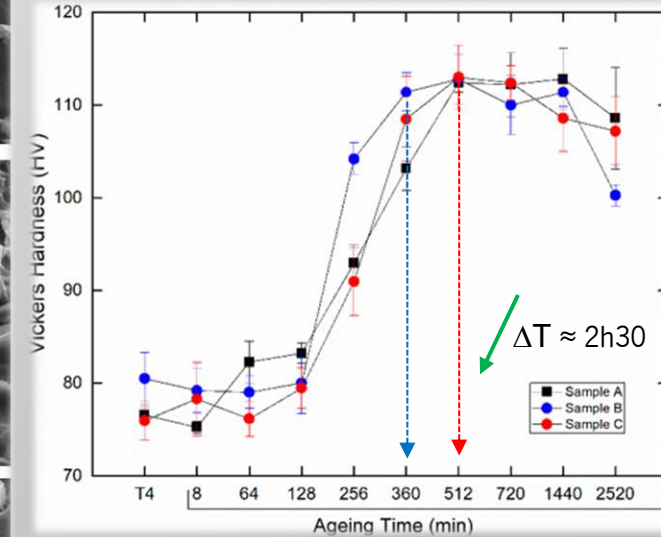

Vickers hardness values for solution-treated samples at various artificial aging times.

Samples	Processing conditions			Description
A	No US treatment			
	US-treatment [Start]	US-treatment [End]		
B	Before pouring	635 °C ± 5 °C		Fully above liquidus
C	630 °C ± 5 °C	550 °C ± 5 °C		Near-liquidus→bellow solidus

Ultrasound-Assisted Liquid Metal Treatment

From laboratory research...

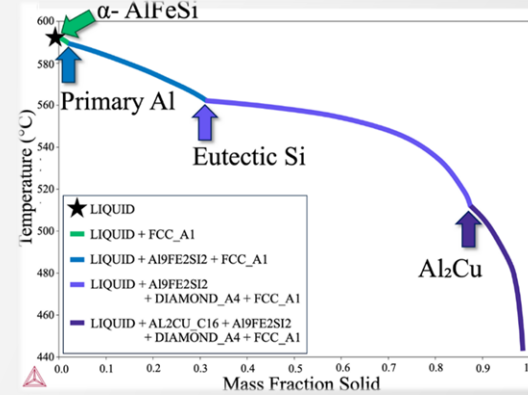

Recycling of Al alloys?

Yes, it is! Using MMM-based!

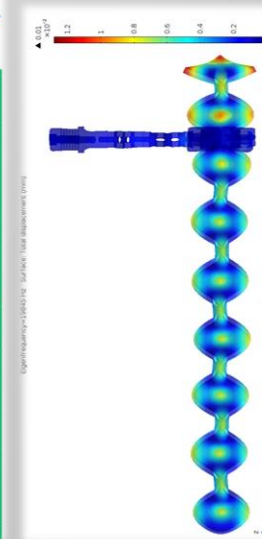
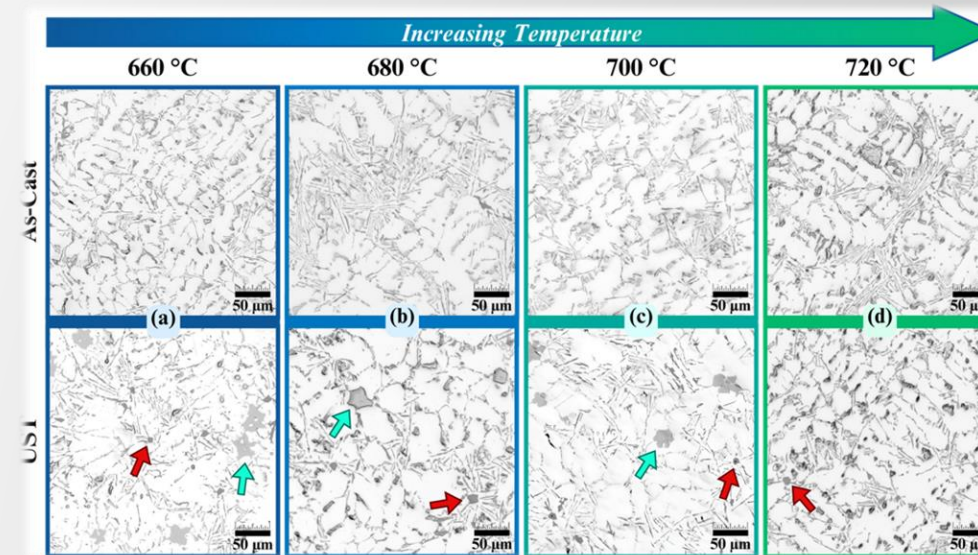

Trials indicate the formation of primary Si and a change in the morphology of the Fe-containing phase. *Red arrows: Si | Teal arrow: Fe*

Ultrasound-Assisted Liquid Metal Treatment

Dynamic Stirring rotation
available for degassing of aluminum alloys in a
furnace / crucible

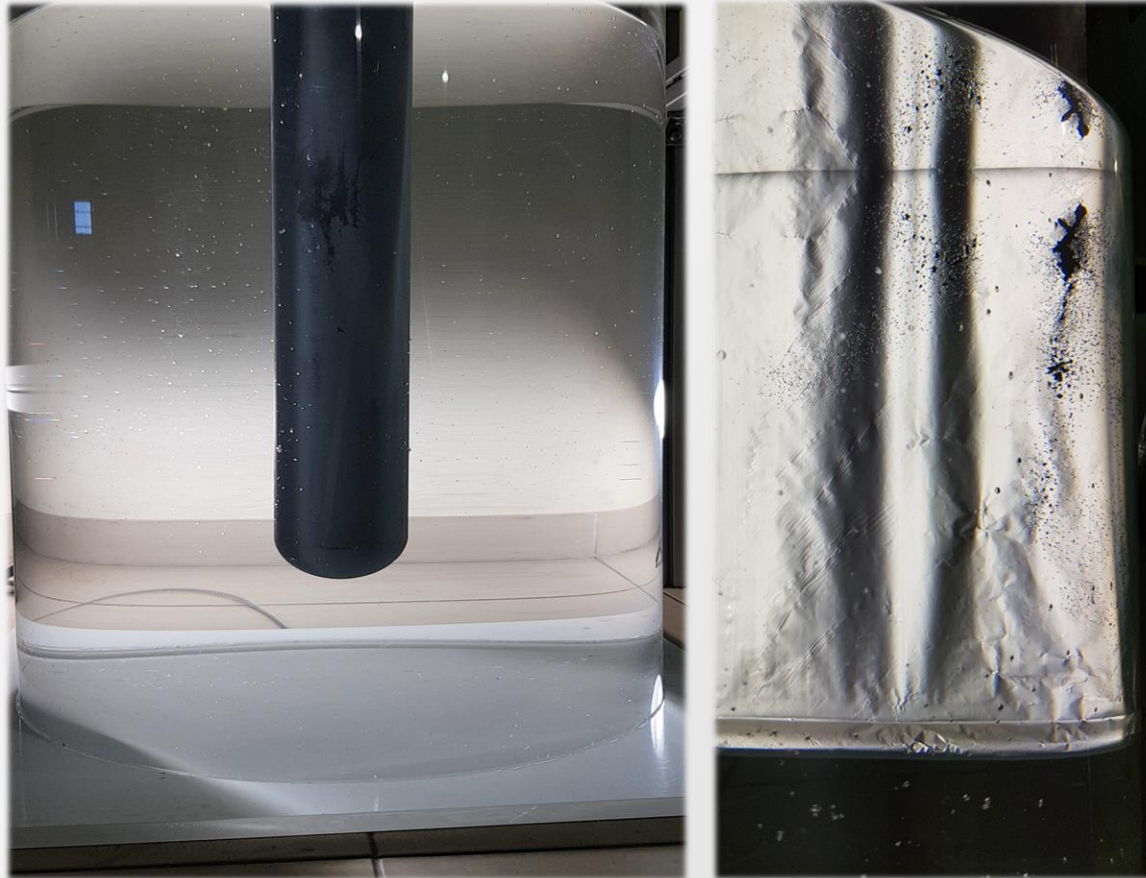

Ultrasound-Assisted Liquid Metal Treatment

From laboratory research... **to industrial application!**

Die Casting Gravity

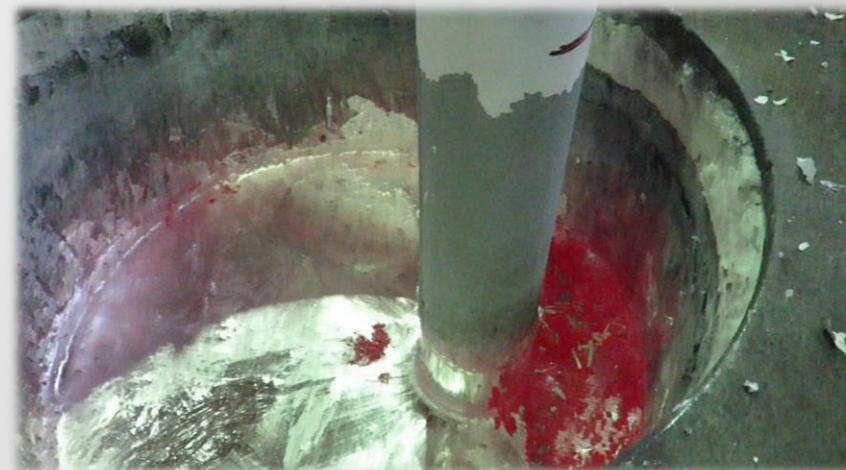

AlSi7Mg alloy
T = 700 °C
US MMM with **f = 19.8±0.4 kHz**
P = 600 W

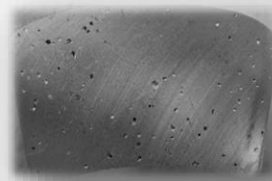

0 min



1 min

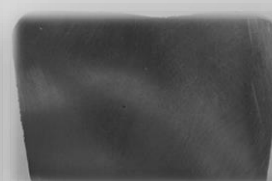

3 min



5 min

Ultrasound-Assisted Liquid Metal Treatment

From laboratory research... **to industrial application!**

Rheocasting

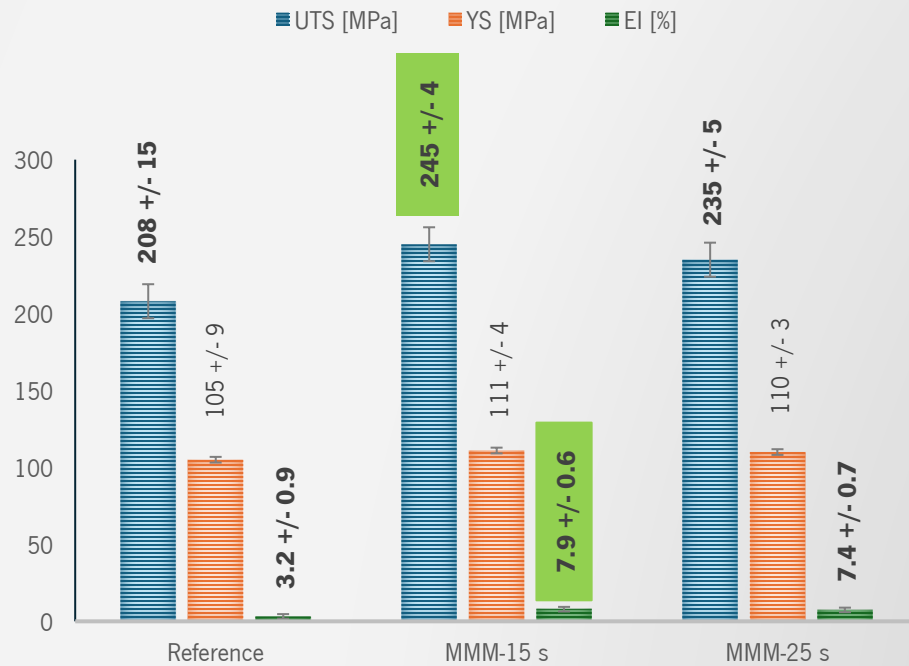

AlSi7Mg alloy
T = 700 - 680 °C
 ON = 5 s / OFF = 2 s
 US MMM with **f = 19.8±0.4 kHz**
 P = 600 W

Density-Index (Ladle 2 kg) = 0.8 - 1.0



Ultrasound-Assisted Liquid Metal Treatment

From laboratory research... **to industrial application!**

High Pressure Die Casting

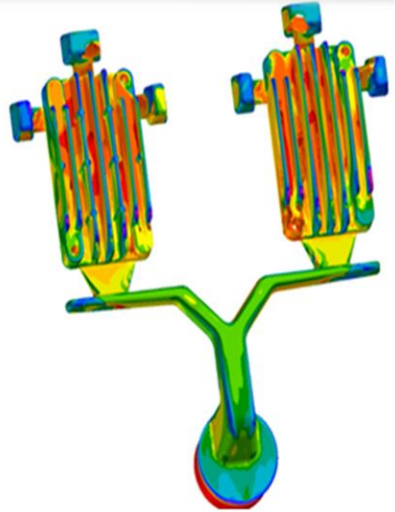
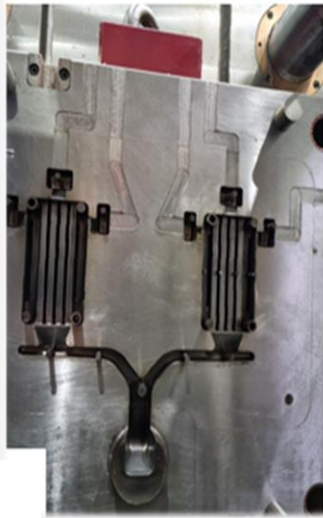



Ultrasound-Assisted Liquid Metal Treatment

From laboratory research... to industrial application!

Continuous Casting (Twin-Roll)

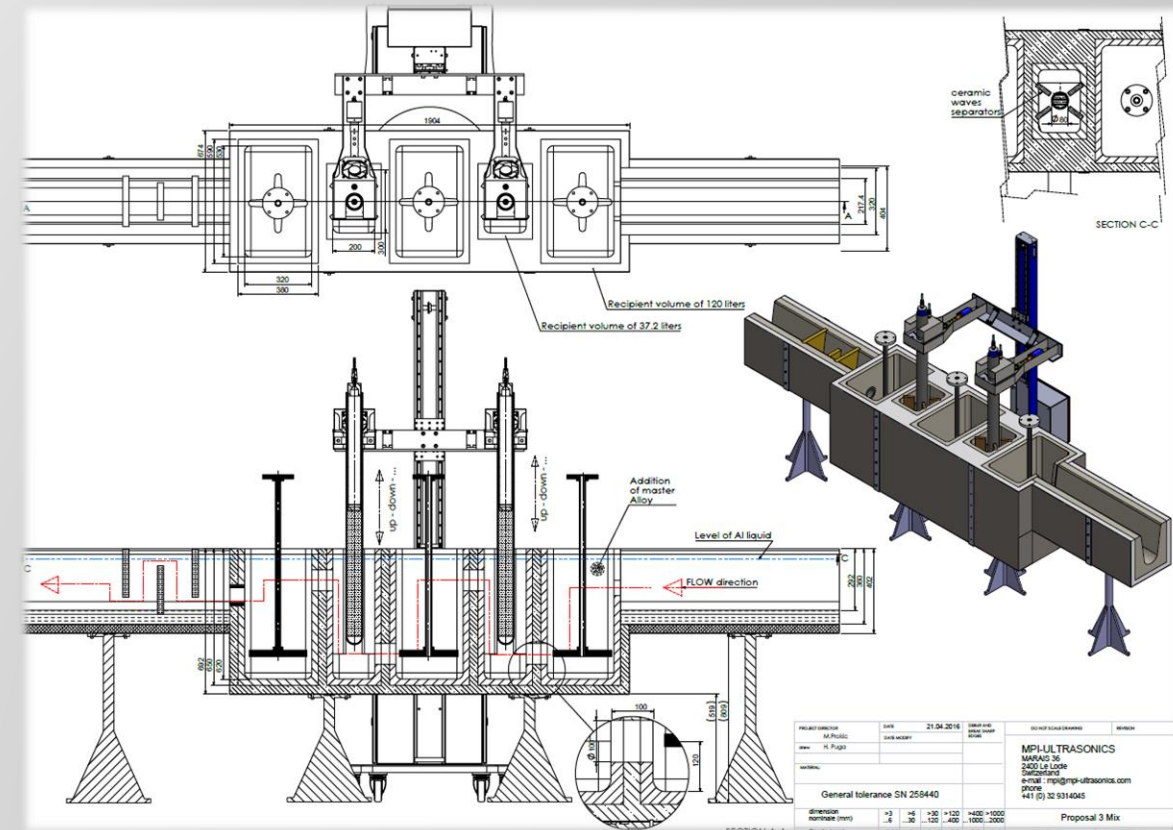
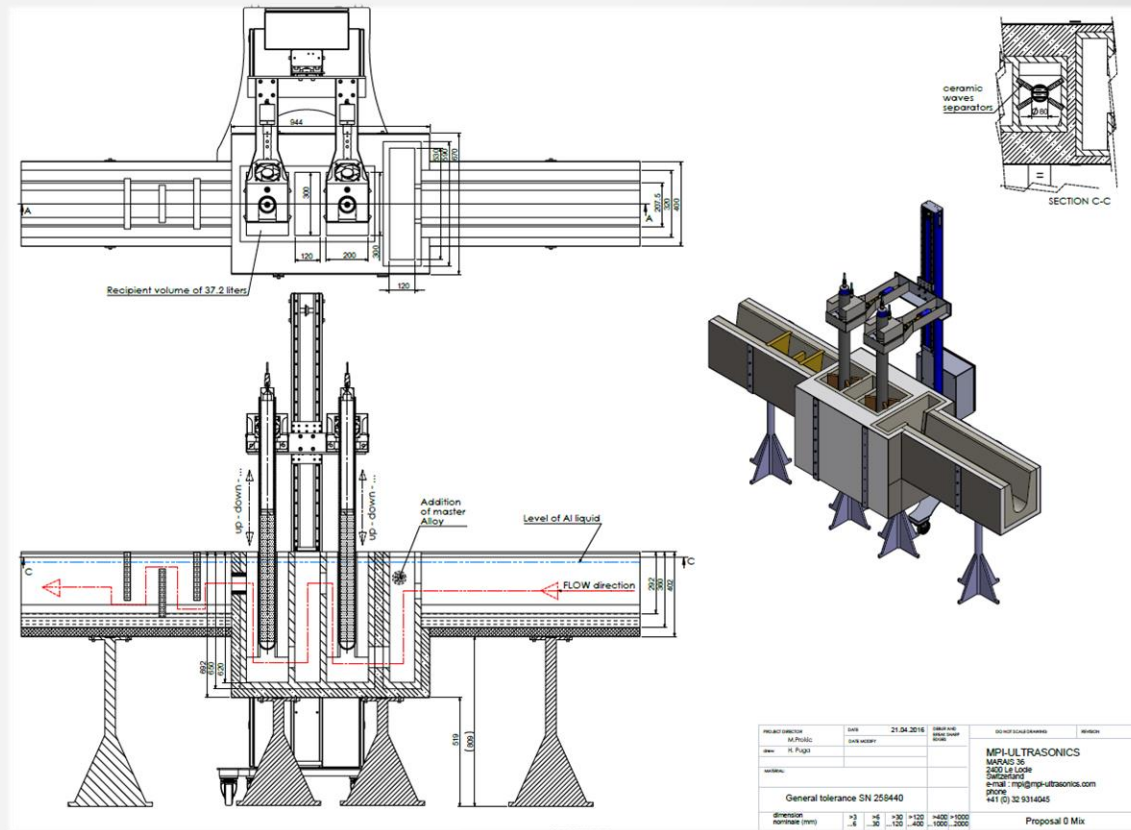

Ultrasound-Assisted Liquid Metal Treatment

From laboratory research... **to industrial application!**

Continuous Casting (Twin-Roll)

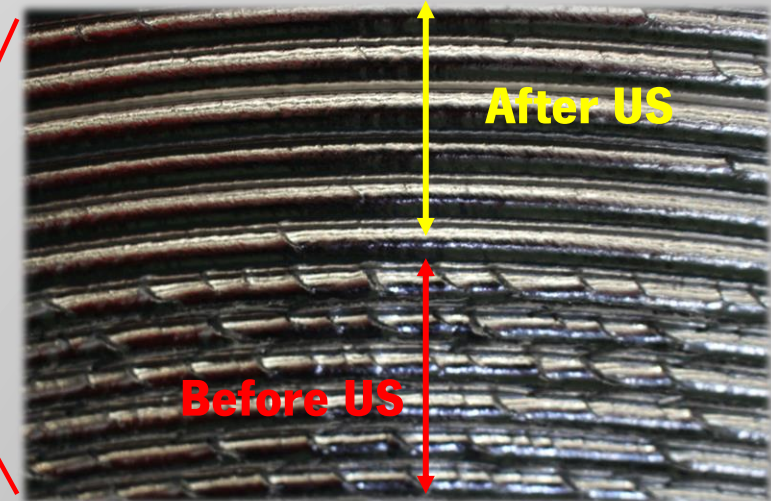
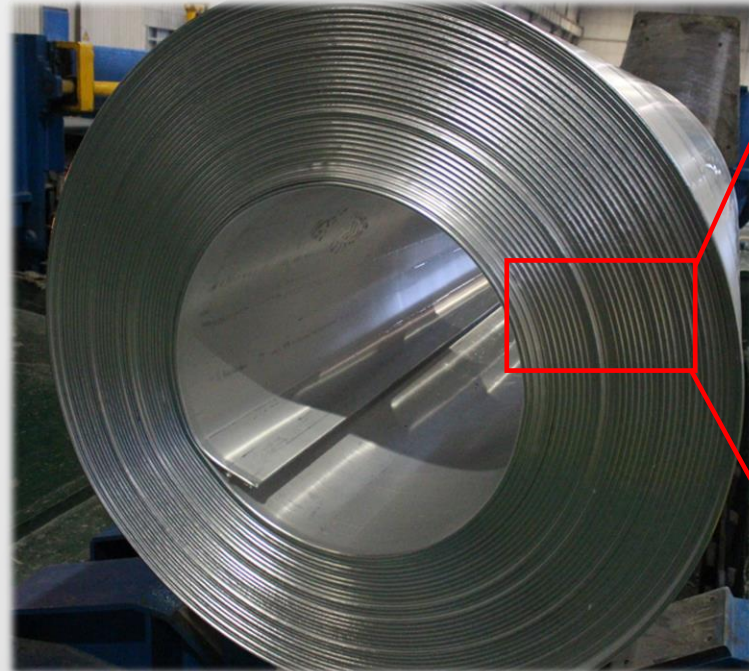

Ultrasound-Assisted Liquid Metal Treatment

Casting magnesium alloys...

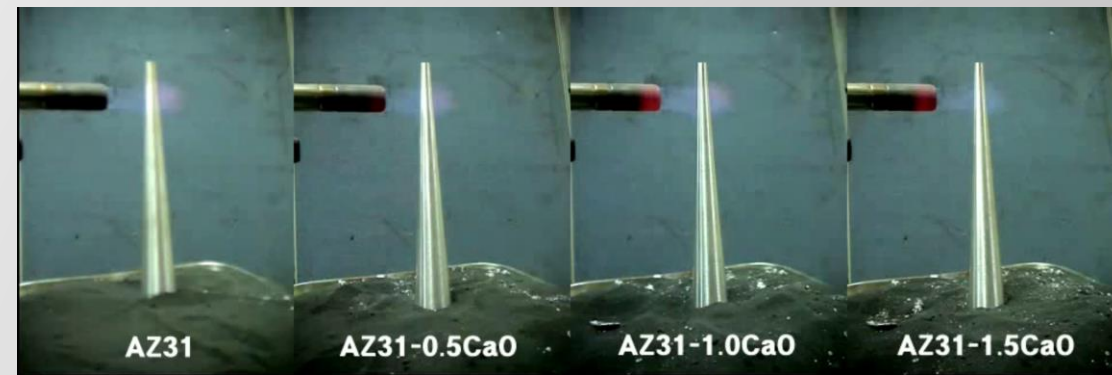

Ultrasound-Assisted Liquid Metal Treatment

Casting magnesium alloys...

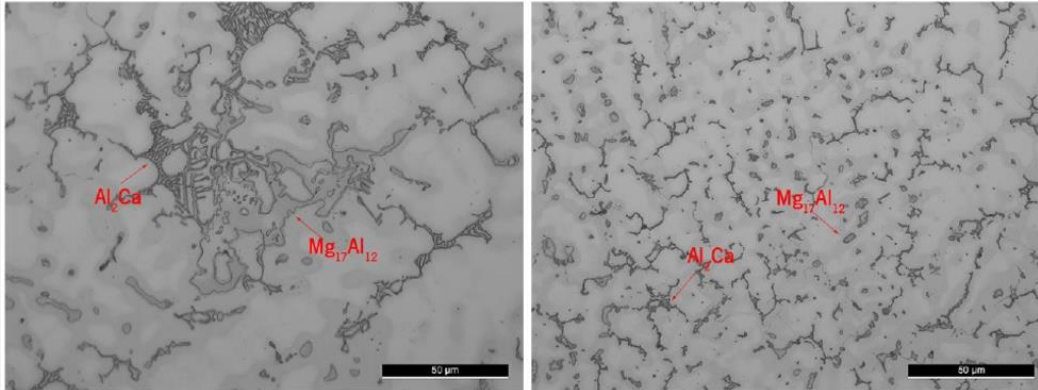

Microstructure of non- and US-treated samples in the as-cast condition

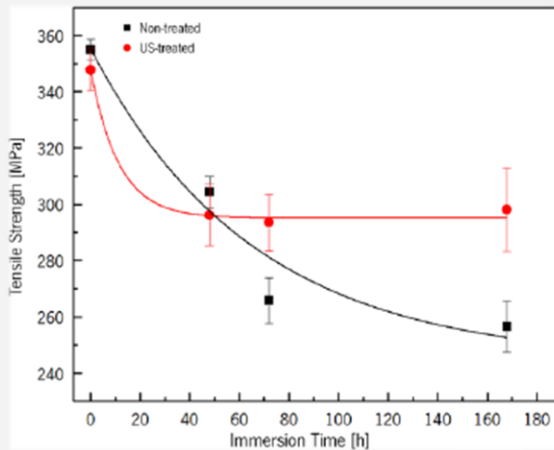

Mechanical properties of the non- and US-treated wires: ultimate tensile strength, elongation at break.

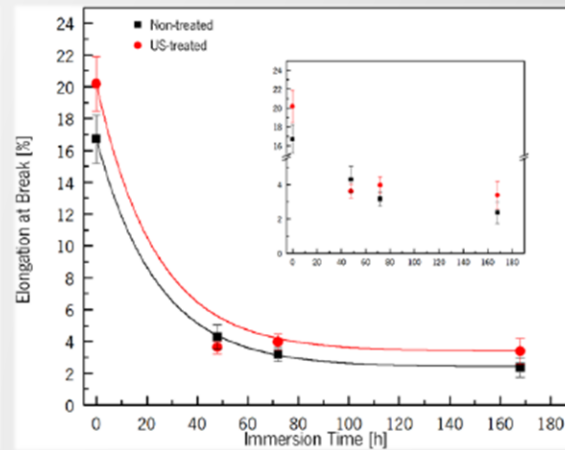

Mechanical and Corrosion Properties of Extruded AZ91D-1%Ca Wires

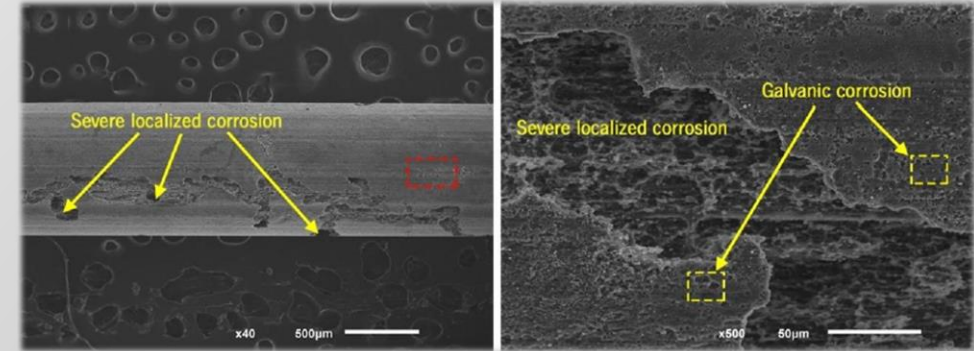

Surface morphology of the non-treated samples before and after removal of corrosion products – 7 days immersion.

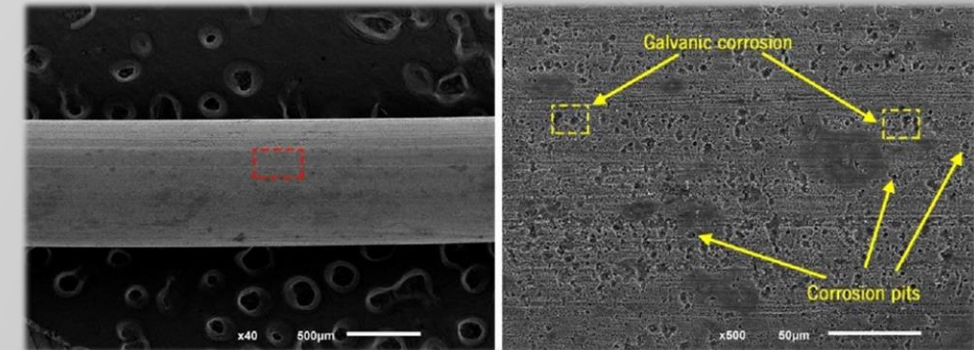

Surface morphology of the US-treated samples before and after removal of corrosion products – 7 days immersion.

Conclusions and Future Perspectives

Lightweight alloy production is evolving, driven by technological advancements and demand for efficient, sustainable materials.

Processes like **ultrasonic melt treatment** ensure desired properties. Innovations melt treatment, advanced alloys, **sustainable processes**, and **digitalization** are transforming the industry, meeting automotive and aerospace demands while **improving efficiency and sustainability**.

The continuous advancements in materials and processes are driving technological progress and enhancing global competitiveness.

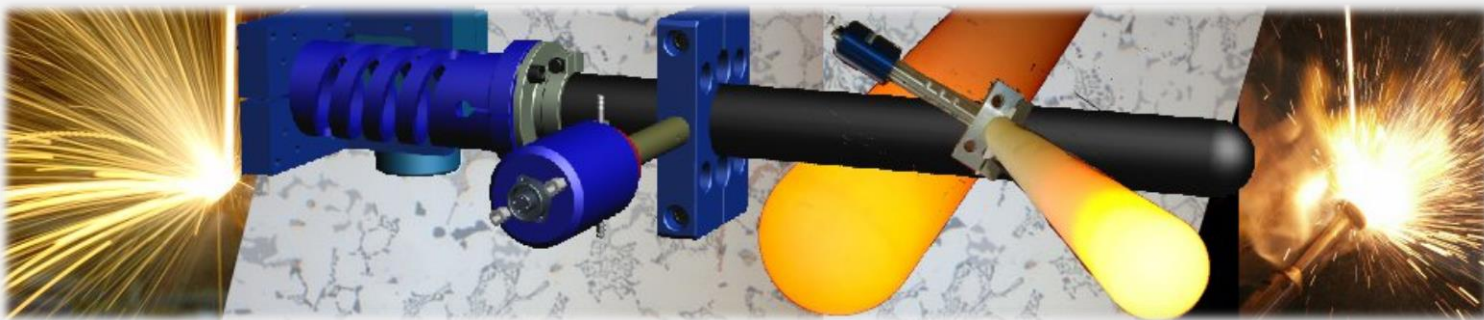

www.UltrasonicMetallurgy.com

The future of your company start here with ... with **MMM** Technology

Thank You.

MP Interconsulting
Marais 36,
2400 Le Locle, Switzerland
www.UltrasonicsWorldGroup.com

Phone: +41-32-9314045
Fax: +41-32-9314079
www.mpi-ultrasonics.com
mpi@mpi-ultrasonics.com

Patent

European Patent Application (related to MMM technology): EP 1 238 715 A1
Multifrequency ultrasonic structural actuator
Applicant: **Prokic Miodrag**, MP Interconsulting, 5.03.2001 – 11.09.2002